

Check valve

Type RVM/RVH

up to 700 bar
up to 45 l/min

Features

- Leakage free in closed position
- With open or closed flow in direction of screwing-in
- Screw-in thread G1/8 and G 1/4, G3/8 and 9/16-18 UNF



Design

- Seated valve
- Cartridge type

Applications

It is a spring-loaded seat valve. The check valve is used for blocking of the flow in one and low-loss flow in the other direction. The closing element is guided.

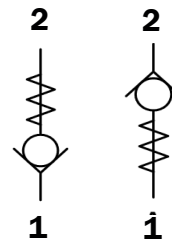

Technical data

Hydraulic fluid	mineral oil according to DIN 51524 part 1 and 2 (other fluids on request)
Fluid temperature range	-20 to 120 °C
Ambient temperature range	-20 to 120 °C
Viscosity range	2.8 to 800 mm ² /s
Max. flowrate	20 to 45 l/min
Max. operating pressure port A	500 (RVM) resp. 700 bar (RVH)
Max. operating pressure port R	500 (RVM) resp. 700 bar (RVH)
Max. Pressure loss	see pressure loss chart
Opening pressure	0,138 bar
Filtration (recommendation)	According to NAS 1638, class 10 resp. ISO/DIN 4406 class 21/19/16
Materials	Valve: free-cutting steel (hardened) Ball: bearing steel Seat: free-cutting steel (hardened)

Type RVM/RVH

up to 700 bar
up to 45 l/min

Key sheet

Example	RV	M	G1/8	A	V	A	00
Check valve							
Type	M	500 bar					
	H	700 bar					
Design							
G1/8	G1/8 Screw-in thread						
G1/4	G1/4 Screw-in thread						
G3/8	G3/8 Screw-in thread						
9/16-18 UNF	9/16-18 UNF Screw-in thread						
Flow direction	A (open from 1 to 2; see product information)						
	R (closed from 1 to 2; see product information)						
Seals	V (FPM)						
	other material on request						
						Special design	
						01 ... 99	
						(00 for standard)	
						Part index	
						Please leave blank (small	
						letters a-d; different letters do	
						not effect interchangeability)	
						Desing revision	
						Capital letters A-Z; identical letters	
						equal same connecting dimensions	

Product information

Type	Design	max. p [bar]	max. Q [l/min]	opening pressure [bar]	pressure loss * [bar]	Part number
RVM-G1/4-A-V-A*00	A	500	30	0,138		4094934
RVM-G1/4-R-V-A*00	R	500	20	0,138		4094945
RVM-G3/8-A-V-A*00	A	500	45	0,138		4094946
RVM-G3/8-R-V-A*00	R	500	30	0,138		4094947
RVM-9/16-18UNF-A-V-A*00	A	500	30	0,138		4094948
RVM-9/16-18UNF-R-V-A*00	R	500	20	0,138		4094949
RVH-G1/8-A-V-A*00	A	700	10	0,19	3	3831359
RVH-G1/8-R-V-A*00	R	700	8	0,19	10	3831360
RVH-G1/4-A-V-A*00	A	700	25	0,21	3	3831361
RVH-G1/4-R-V-A*00	R	700	20	0,21	8	3831363

* at max. flow rate

Hydraulics schematics version A

with closed flow in screw-in direction



Hydraulic schematics version R

with open flow in screw-in direction



Dimensional drawing A

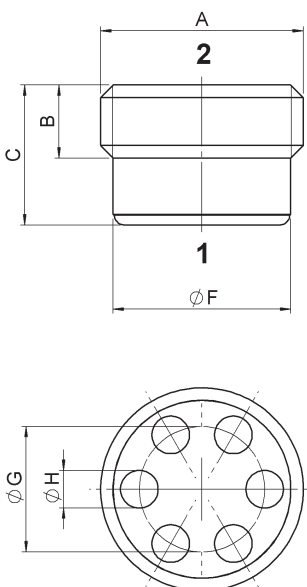

Dimensional drawing R

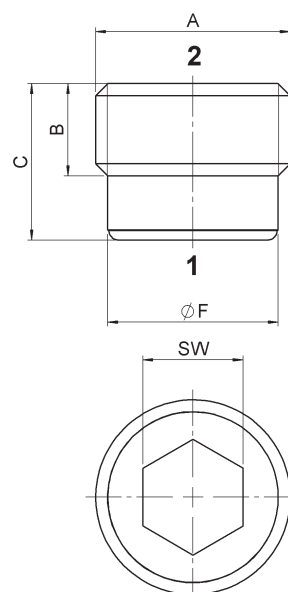

Type RVM/RVH

up to 700 bar
up to 45 l/min

Dimension chart

Type	A	B [mm]	C [mm]	Ø E [mm]	Ø F [mm]	Ø G [mm]	Ø H [mm]	SW [mm]	Tightening torque* [Nm]
RVM-G1/4-A-V-A*00	G1/4	4,7	9,2	2,4	11,4	8,6	2,2	-	10
RVM-G1/4-R-V-A*00	G1/4	5,15	9,5	2	11,4	-	-	5	8
RVM-G3/8-A-V-A*00	G3/8	6,7	11,5	3	14,9	10,8	3,1	-	15
RVM-G3/8-R-V-A*00	G3/8	6,4	11,1	2,4	14,9	-	-	7	15
RVM-9/16-18UNF-A-V-A*00	9/16-18UNF	4,8	9,6	2,4	12,5	8,6	2,2	-	10
RVM-9/16-18UNF-R-V-A*00	9/16-18UNF	5,5	10	2	12	-	-	5	8
RVH-G1/8-A-V-A*00	G1/8	3,5	6,7	-	8,5	6	1,8	-	12
RVH-G1/8-R-V-A*00	G1/8	4,6	7,8	-	8,5	-	-	5	12
RVH-G1/4-A-V-A*00	G1/4	4,2	8,2	2,4	11,4	9	2,2	-	20
RVH-G1/4-R-V-A*00	G1/4	6,3	10	2	11,4	-	-	7	20

* If required, the valves must be secured additionally against becoming loose by an adequate measure.

Cavity drawing

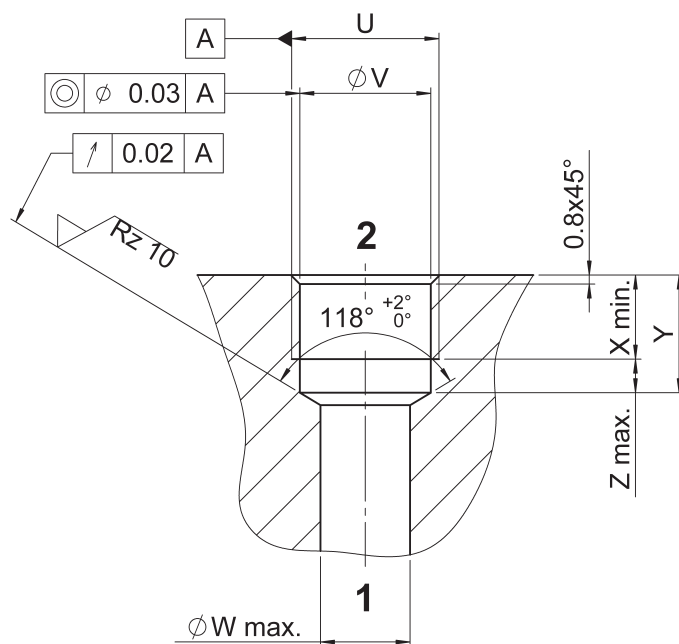

Type	U	Ø V [mm]	Ø W [mm]	X min [mm]	Y [mm]	Z max [mm]
RVM-G1/4-...	G1/4	11,7 ^{+0,1}	8	7,5	10,5	3
RVM-G3/8-...	G3/8	15,2 ^{+0,1}	10	9	12	3
RVM-9/16-18UNF-...	9/16-18UNF	12,8 ^{+0,1}	8	7,5	10,5	3
RVH-G1/8-...	G1/8	8,7 ^{+0,1}	5	6	8,5	2,5
RVH-G1/4-...	G1/4	11,7 ^{+0,1}	8	7,5	10,5	3

Assembly tool

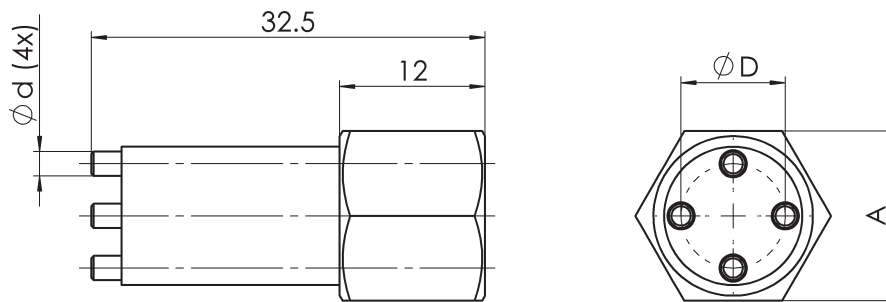
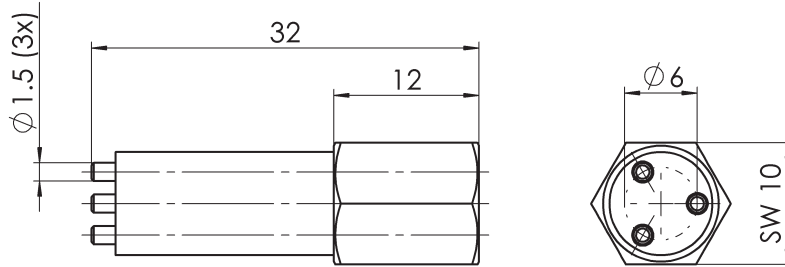

Type	A	ϕd	ϕD	Part number
RVM-G1/4-A...	SW 14	4 x 2	8,6	4066827
RVM-G3/8-A...	SW 17	4 x 3	10,8	4066846
RVM-9/16-18UNF-A...	SW 14	4 x 2	8,6	4066827
RVH-G1/8-A...	SW 10	3 x 1,5	6	4022061
RVH-G1/4-A...	SW 14	4 x 2	9	4022062

Type RVM/RVH

up to 700 bar
up to 45 l/min